

Actual products may differ
from images shown

Specifications:

Power:	4,800 hp (3,581 kW)
Torque:	28,011 lb-ft (37,993 Nm)
Speed:	2,500 rpm
Inertia Value**:	1,187 lb-ft ² (50 kg-m ²)
Shipping Weight:	12,250 lb (5,557 kg)

***With Companion Flange*

For overhung loads, such as a belt or gear drive, please contact Taylor Dynamometer to ensure that the system will meet the required performance needs.

Recommended Accessories:

- Driveshaft
- Driveshaft Guard
- Adapter Plate Kit
- Engine Cart
- Closed Loop Cooling Center
- Air Starter
- Throttle Control
- Water Recirculating System

Optional Accessories



Optional
Closed Loop Cooling Center



Optional Charge
Air Cooler



Optional
Driveshaft Guard



Optional
Engine Cart

Various Facility Support Systems and Services Available



Bulk Fuel Storage
and Distribution



Coolant Storage
and Distribution



Water
Recirculation



Design
Services



Commissioning,
Start-up & Training

DL3606 (US Customary)

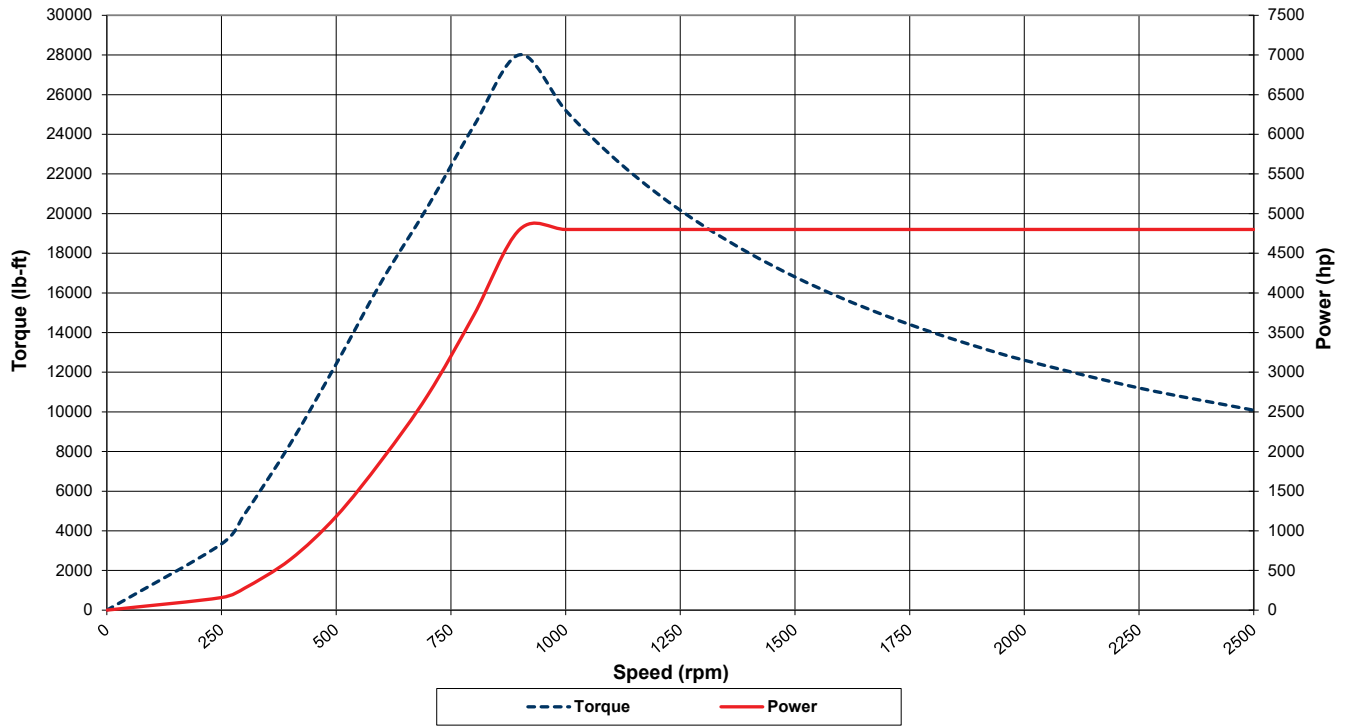

DL3606 (S.I.)

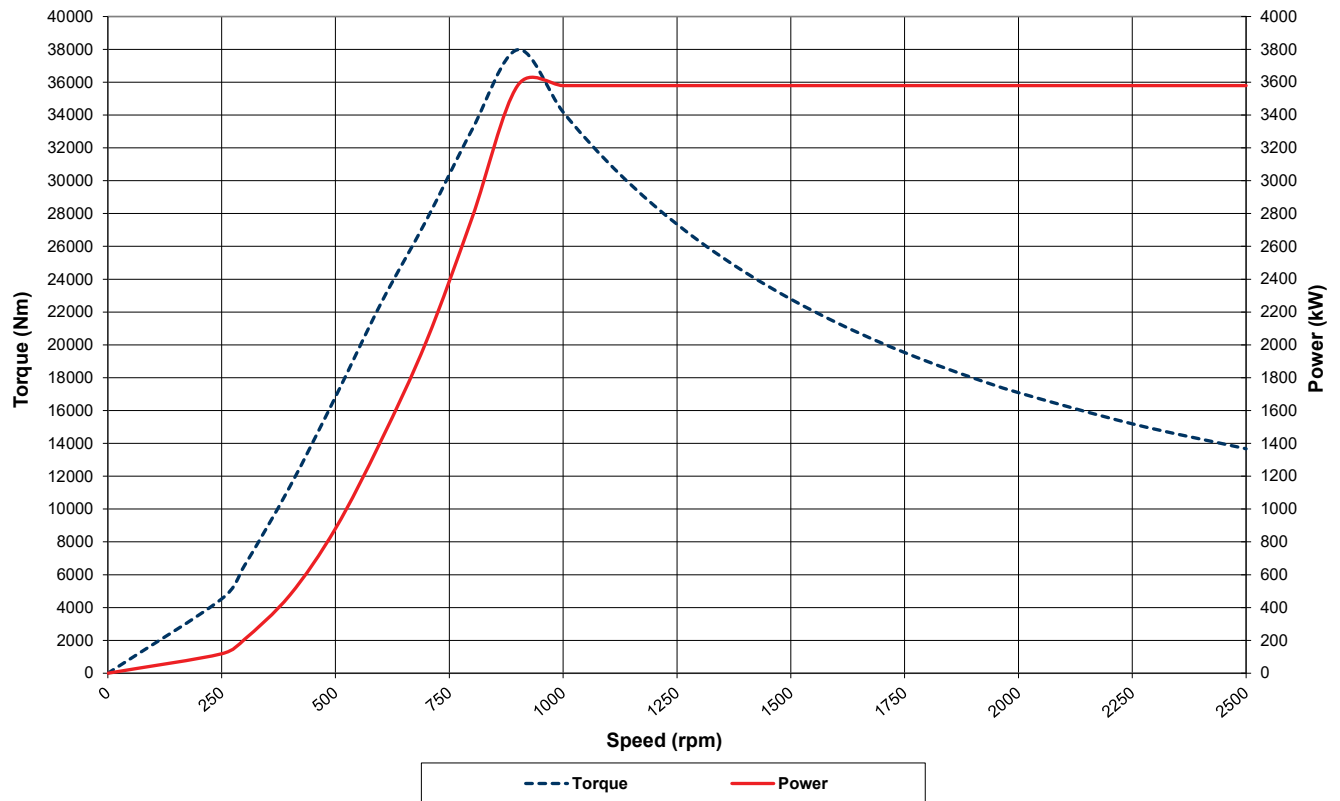

in
(mm)

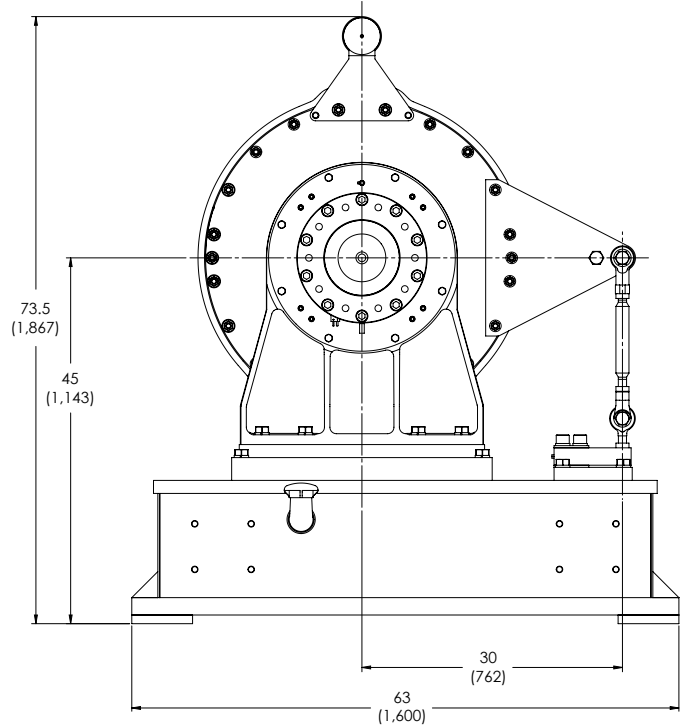
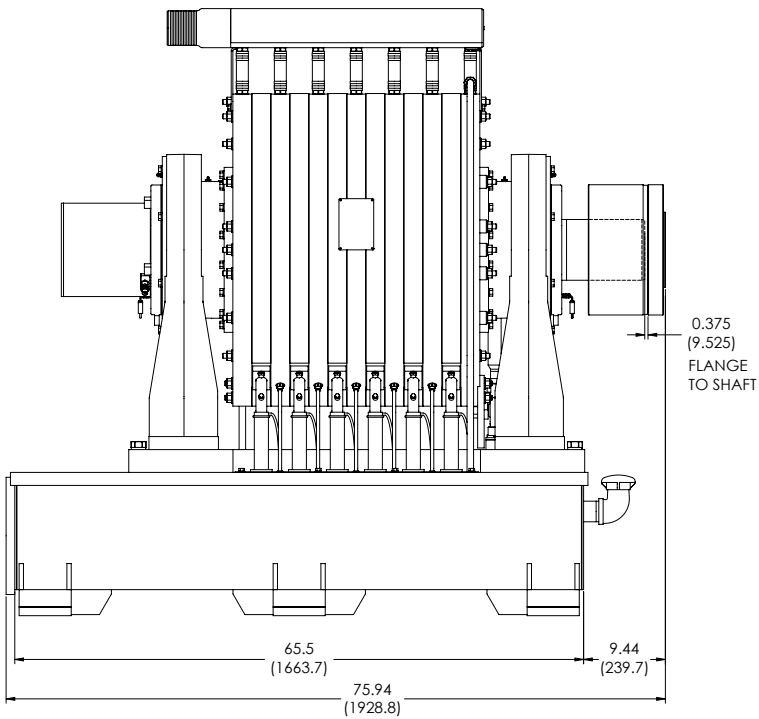

Specifications:

Power:	4,800 hp (3,581 kW)
Torque:	28,011 lb-ft (37,993 Nm)
Speed:	2,500 rpm
Inertia Value**:	1,187 lb-ft ² (50 kg-m ²)
Shipping Weight:	12,250 lb (5,557 kg)

**With Companion Flange

As a safety precaution, Taylor Dynamometer recommends a torsional analysis to uncover any potential torsional problems that exist for each application. This analysis will identify any torsional issues (frequencies) that should be fixed prior to operation. Excessive linear vibration may also create problems that must be mitigated for continued operation. It is the customer's responsibility to ensure that these vibration issues are addressed upon application of the dynamometer. Equipment failures attributed to linear or torsional vibration are not warrantable.