

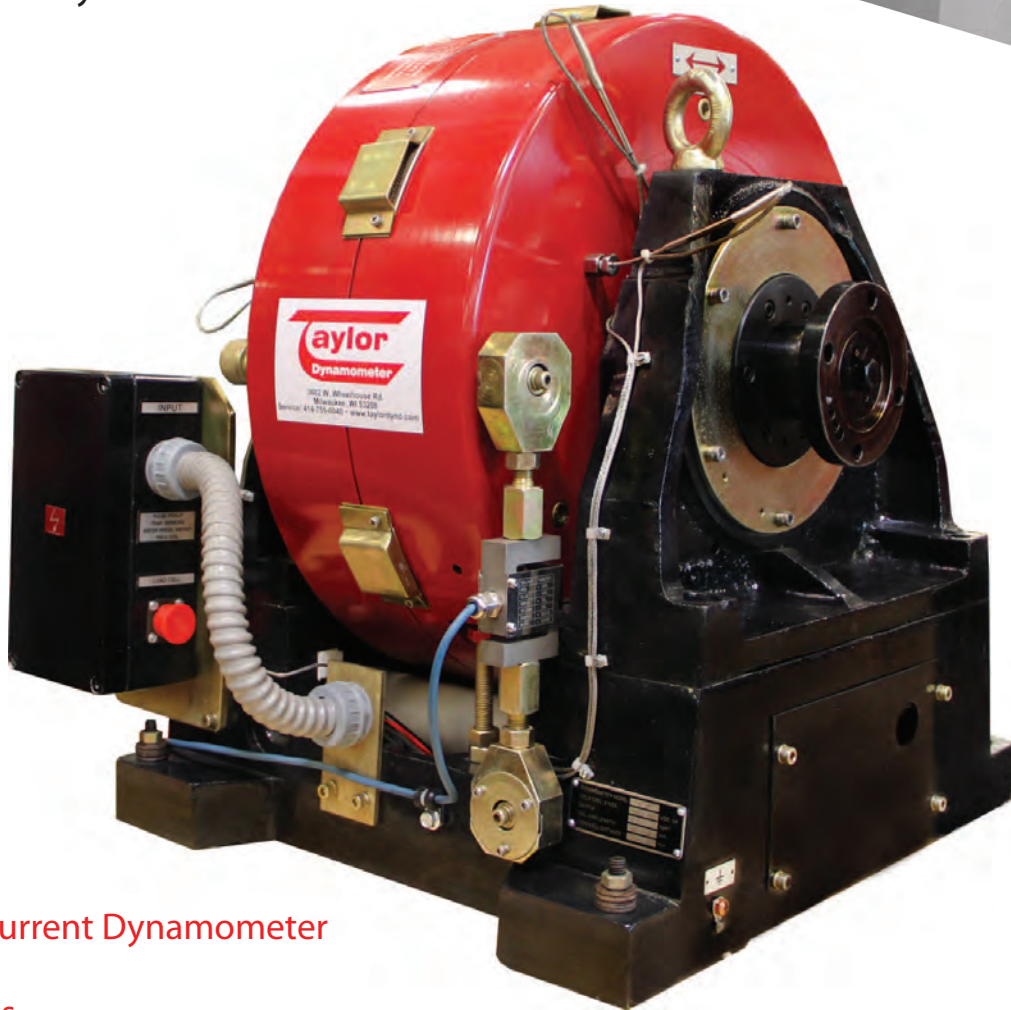

DE20 / Engine Dynamometer



DE20 Eddy Current Dynamometer

Specifications

Power: 27 hp (20 kW)

Torque: 59 ft-lb (80 Nm)

Speed: 12,000 rpm

Water Use: 4 gpm (0.3 lps) (No Cooling System)

Shipping Weight: 904 lb (410 kg)

Inertia Value: 0.30 ft² · lb (0.0125 m² · kg)

Recommended Accessories

- Driveshaft
- Driveshaft Guard
- Test Stand
- Cooling Column
- Engine Cart
- Charge Air Cooler
- Water Recirculating System

Total Test Success

DE20 (English)

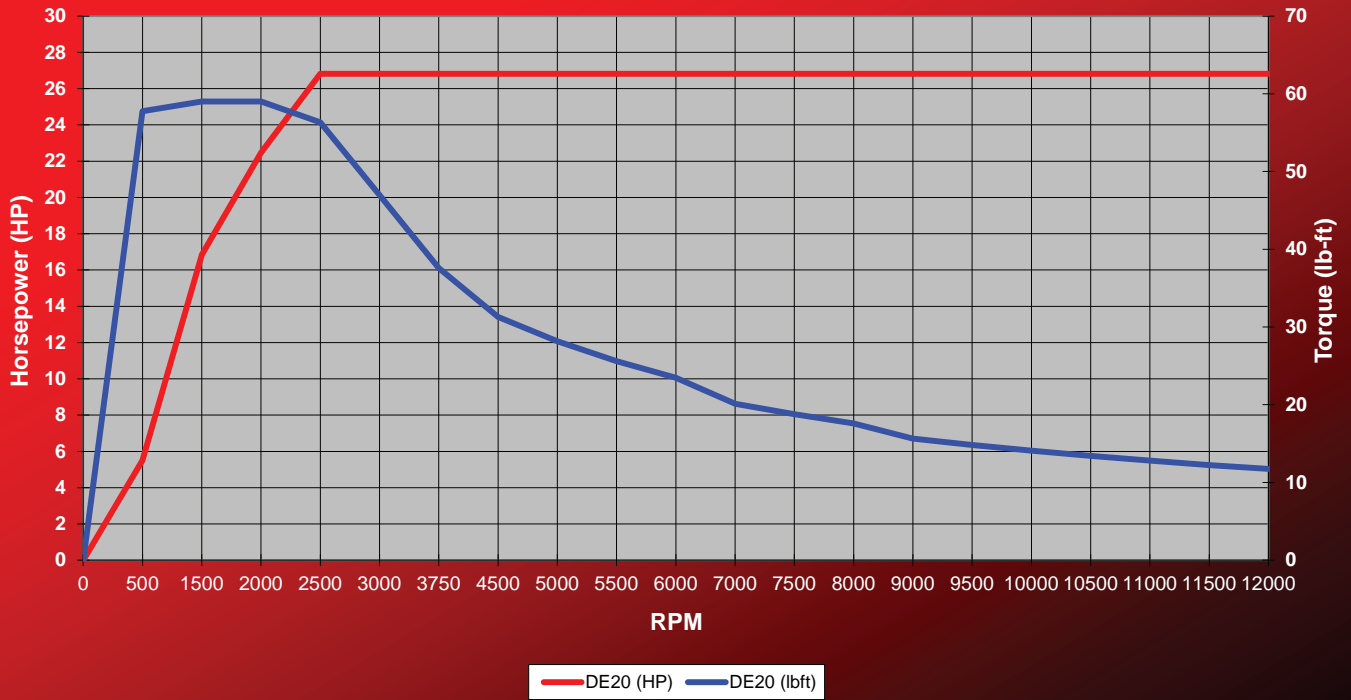

DE20 (Metric)

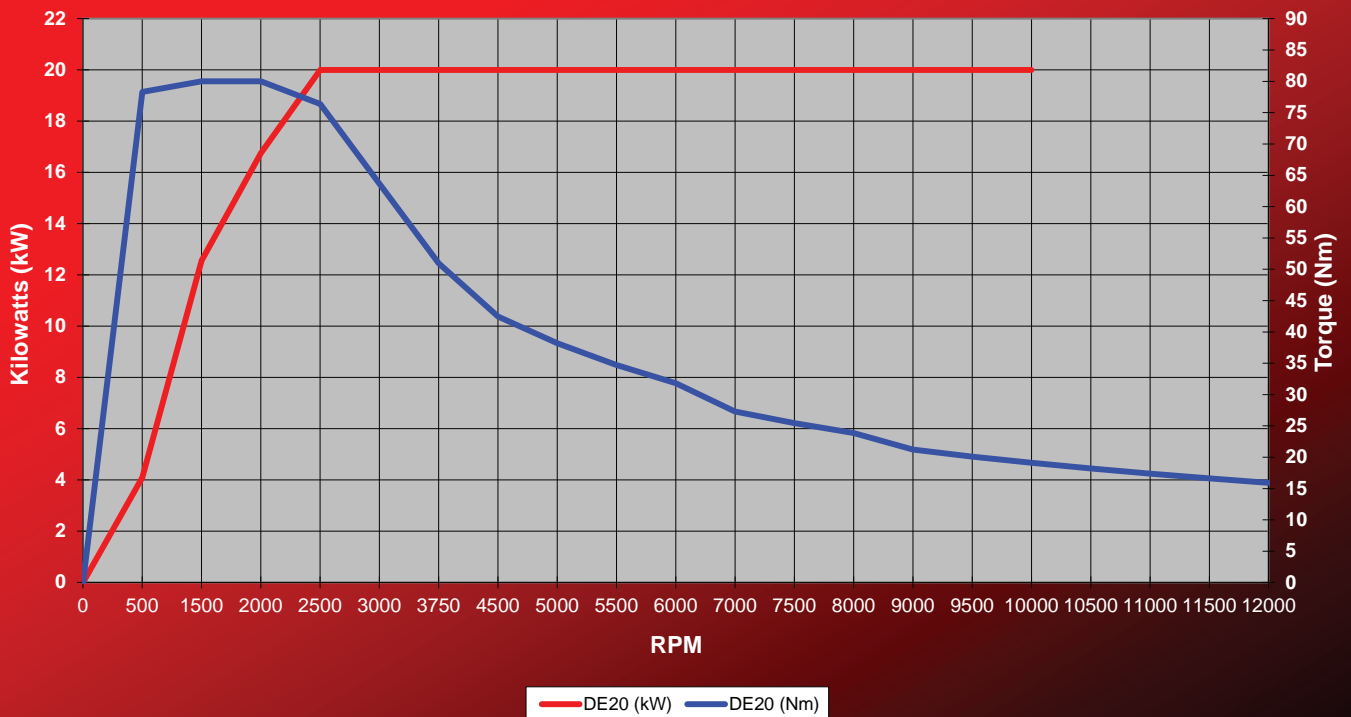

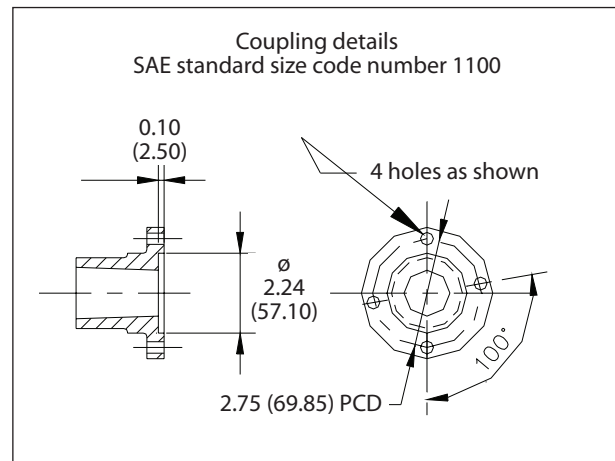
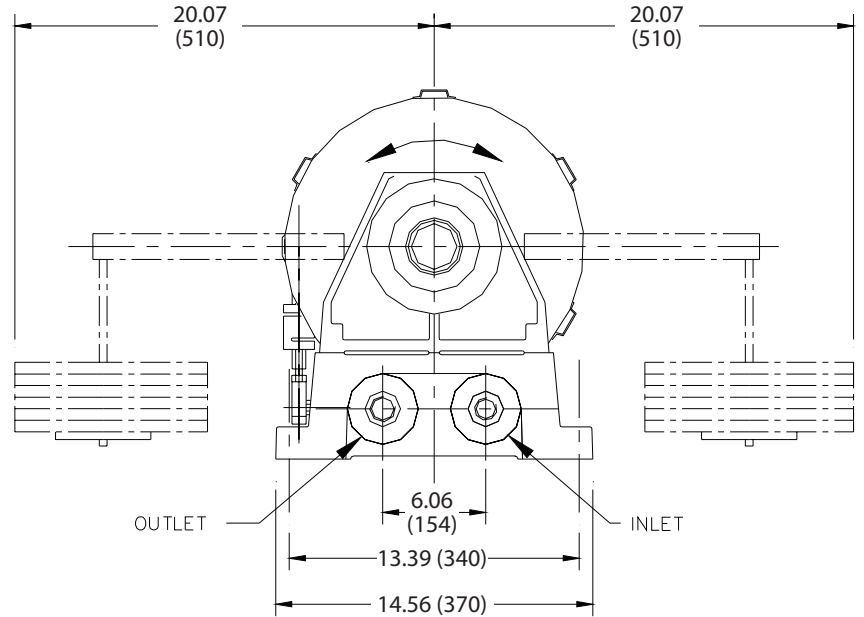
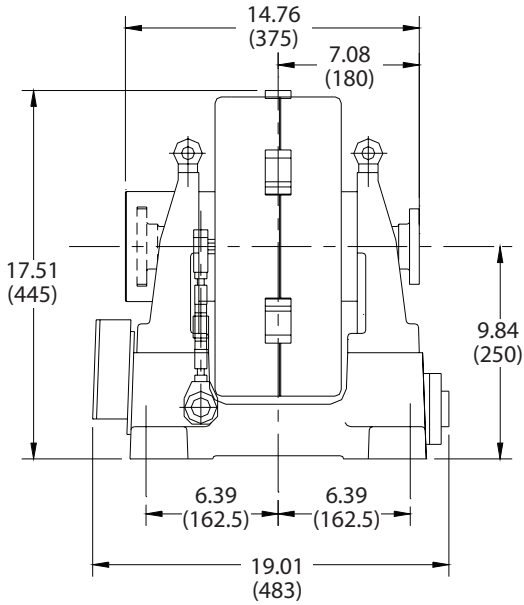

Specifications

Power: 27 hp (20 kW)

Torque: 59 ft-lb (80 Nm)

Speed: 12,000 rpm

Water Use: 4 gpm (0.3 lps) (No Cooling System)

Shipping Weight: 904 lb (410 kg)

Inertia Value: 0.30 ft² · lb (0.0125 m² · kg)

Everything you need to succeed



3602 West Wheelhouse Road, Milwaukee, Wisconsin 53208 U.S.A.
(414) 755-0040 www.taylordyno.com

SMS2025v005