



DE200 / Engine Dynamometer



DE200 Eddy Current Dynamometer

Specifications

Power: 268 hp (200 kW)

Torque: 590 ft-lb (800 Nm)

Speed: 8,000 rpm

Water Use: 37 gpm (2.3 lps) (No Cooling System)

Shipping Weight: 1,863 lb (845 kg)

Inertia Value: 8.28 ft² · lb (0.349 m² · kg)

Recommended Accessories

- Driveshaft
- Driveshaft Guard
- Adapter Plate Kit
- Base Kit
- Engine Cart
- Cooling Column
- Charge Air Cooler
- Water Recirculating System

Total Test Success

Optional Accessories

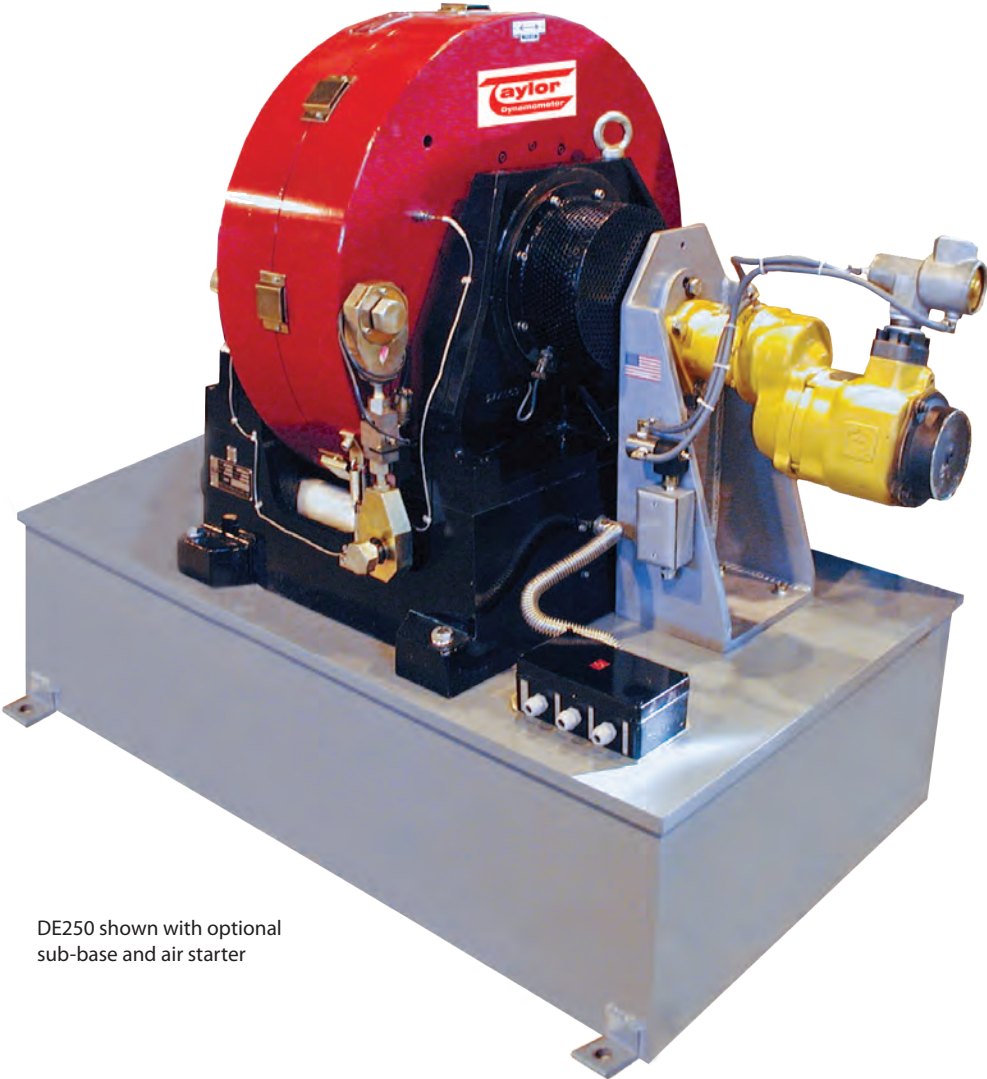

DE250 shown with optional sub-base and air starter

Optional Cooling Column



Optional Engine Cart (Engine not Included)



Optional Driveshaft Cover



Optional Charge Air Cooler



DE200 (English)



DE200 (Metric)



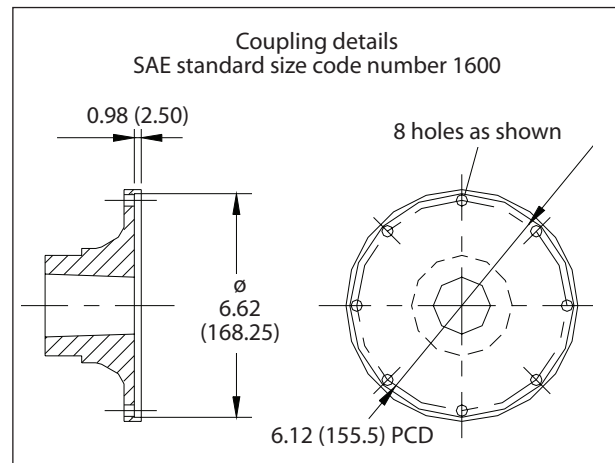
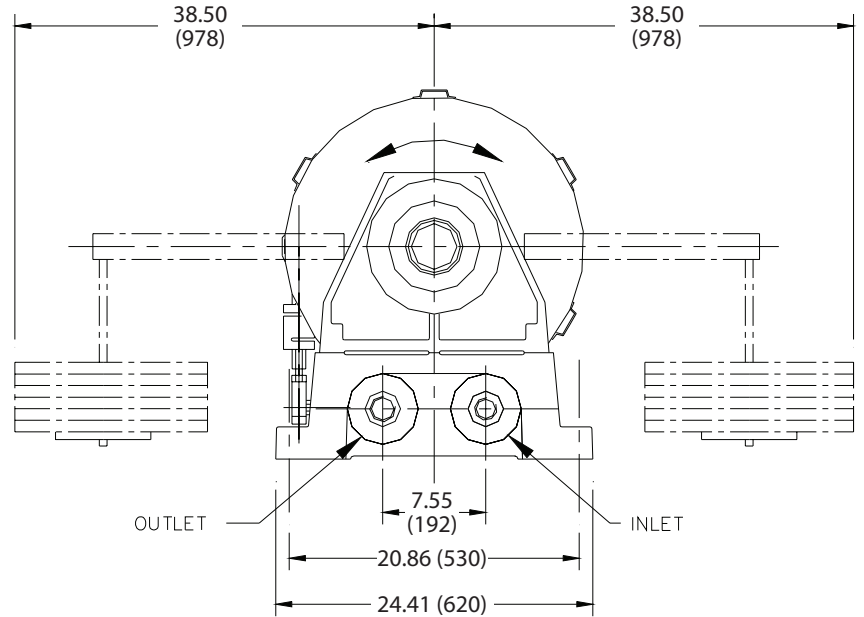
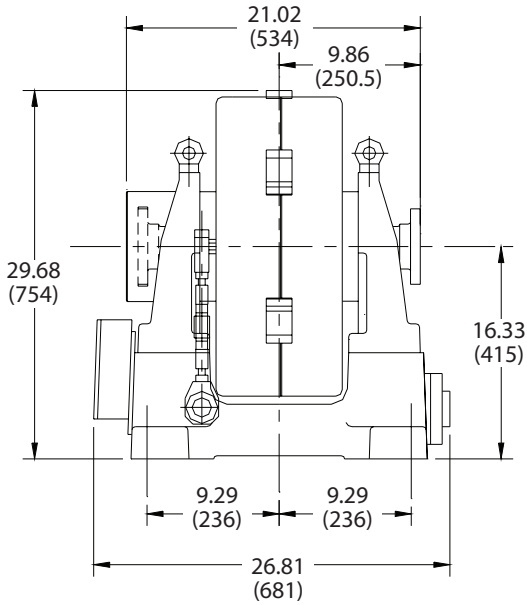

Specifications

Power: 268 hp (200 kW)

Torque: 590 ft-lb (800 Nm)

Speed: 8,000 rpm

Water Use: 37 gpm (2.3 lps) (No Cooling System)

Shipping Weight: 1,863 lb (845 kg)

Inertia Value: 8.28 ft² · lb (0.349 m² · kg)

Everything you need to succeed



3602 West Wheelhouse Road, Milwaukee, Wisconsin 53208 U.S.A.
(414) 755-0040 www.taylordyno.com

SMS2029v004