



## DE720 / Engine Dynamometer



### DE720 Eddy Current Dynamometer

#### Specifications

Power: 966 hp (720 kW)

Torque: 3,320 ft-lb (4,500 Nm)

Speed: 3,750 rpm

Water Use: 124 gpm (7.8 lps) (No Cooling System)

Shipping Weight: 9,259 lb (4,200 kg)

Inertia Value: 126 ft<sup>2</sup> · lb (5.3 m<sup>2</sup> · kg)

#### Recommended Accessories

- Driveshaft
- Driveshaft Guard
- Adapter Plate Kit
- Base Kit
- Engine Cart
- Cooling Column
- Charge Air Cooler
- Water Recirculating System

**Total Test Success**

# Optional Accessories

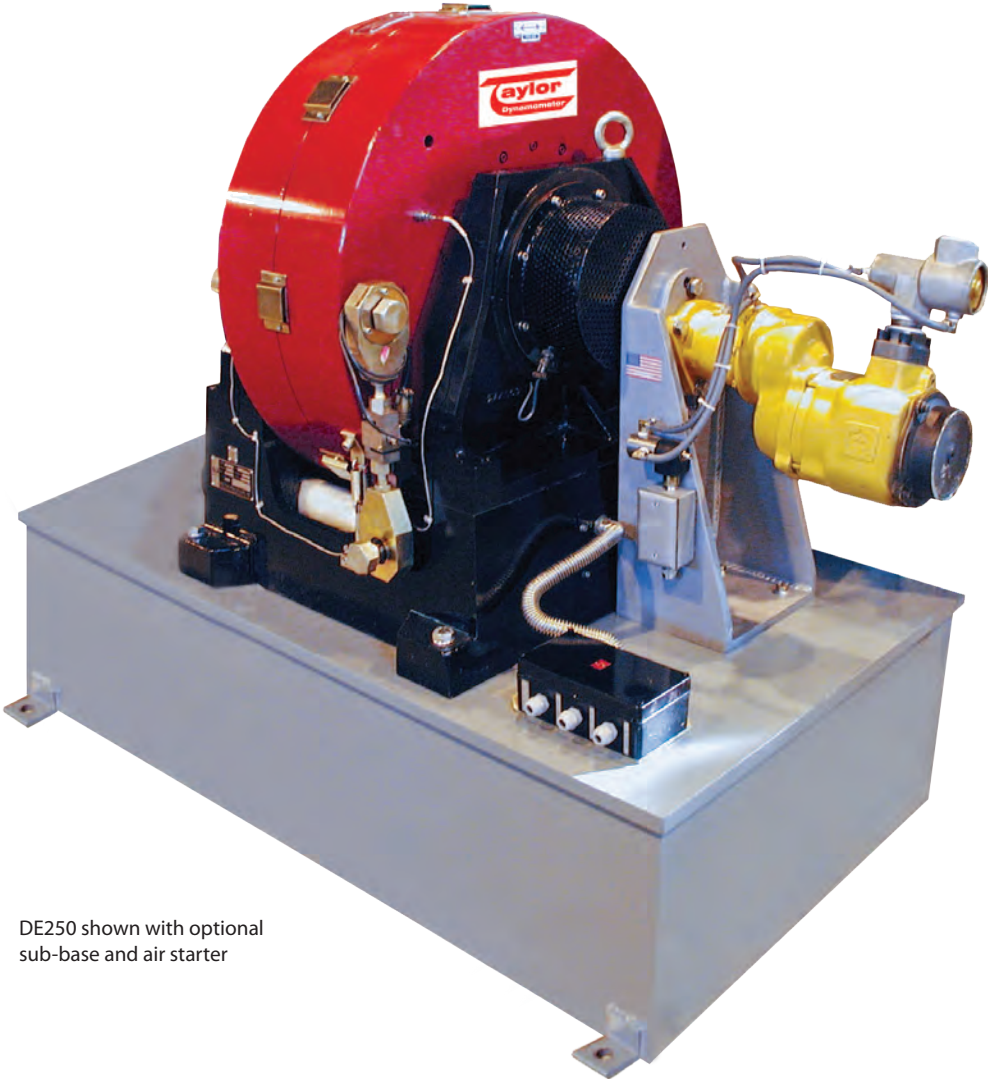

DE250 shown with optional sub-base and air starter

Optional Cooling Column



Optional Engine Cart (Engine not Included)



Optional Driveshaft Cover



Optional Charge Air Cooler



### DE720 (English)



### DE720 (Metric)



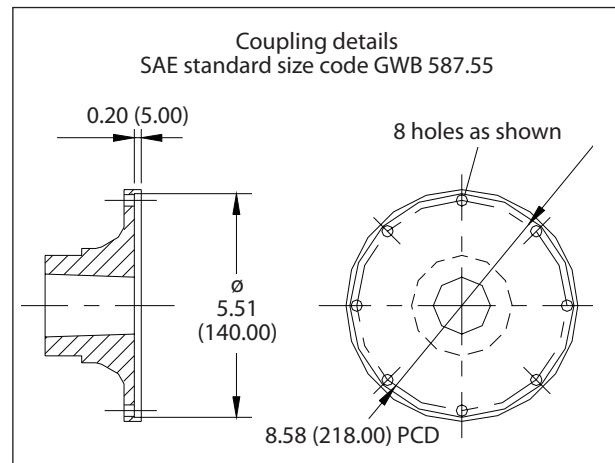
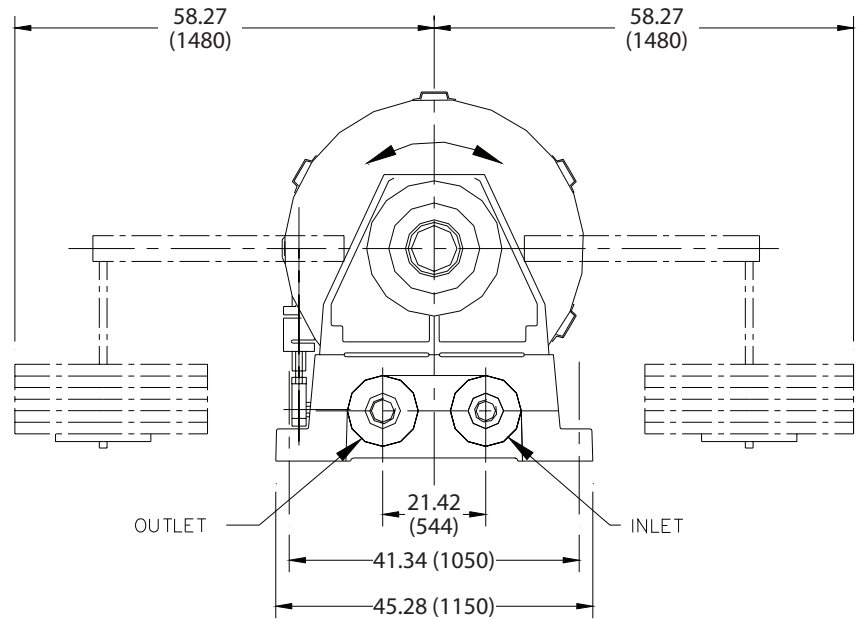
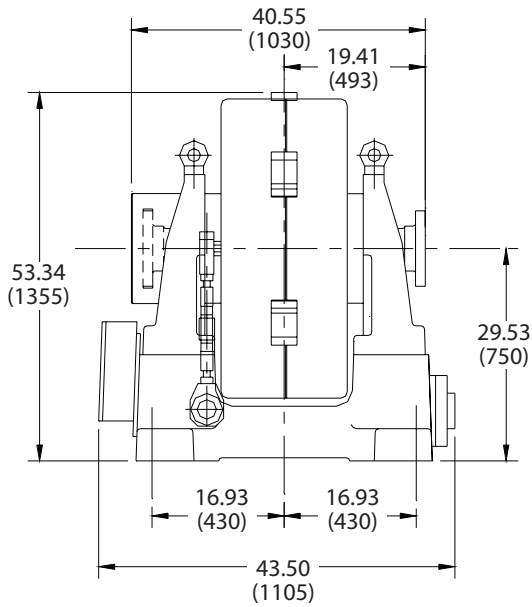

## Specifications

Power: 966 hp (720 kW)

Torque: 3,320 ft-lb (4,500 Nm)

Speed: 3,750 rpm

Water Use: 124 gpm (7.8 lps) (No Cooling System)

Shipping Weight: 9,259 lb (4,200 kg)

Inertia Value: 126 ft<sup>2</sup> · lb (5.3 m<sup>2</sup> · kg)

*Everything you need to succeed*



3602 West Wheelhouse Road, Milwaukee, Wisconsin 53208 U.S.A.  
(414) 755-0040 [www.taylordyno.com](http://www.taylordyno.com)

SMS2033v004