

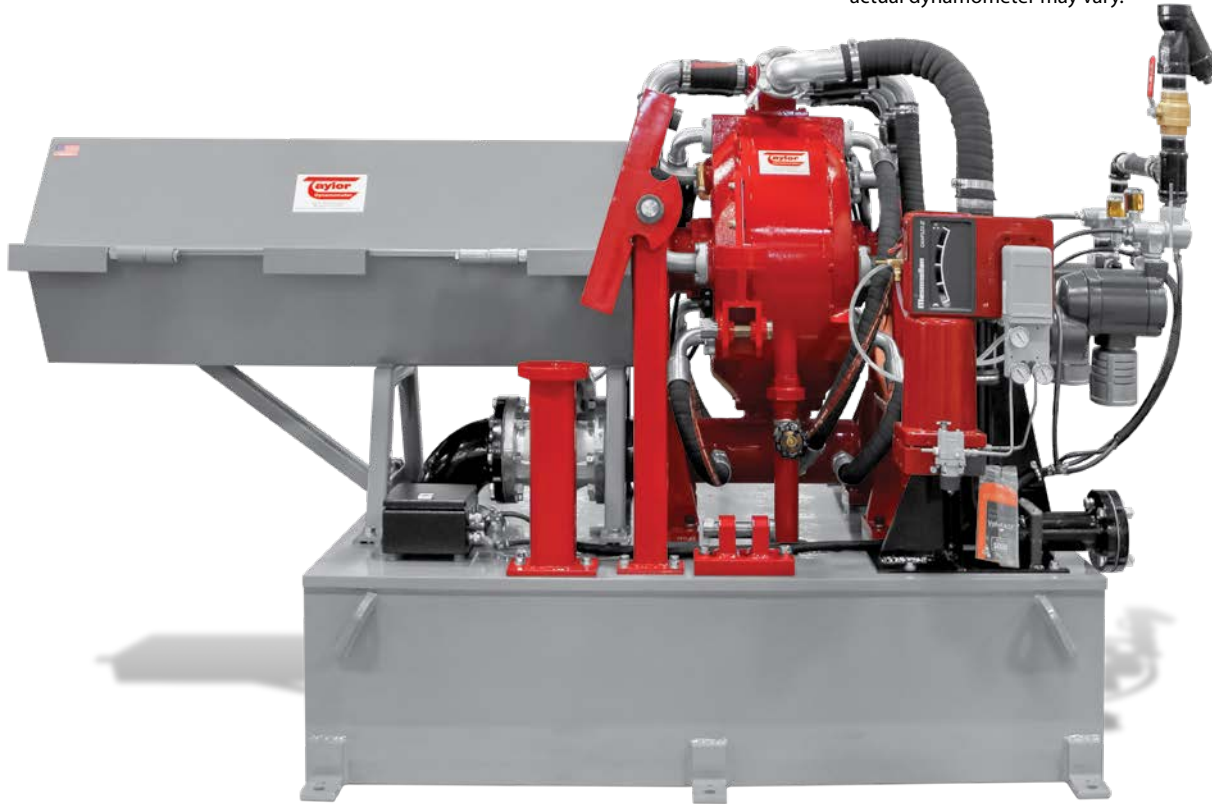

DL10K / Engine Dynamometer

Image shown is for display only,
actual dynamometer may vary.



DL10K Water Brake Dynamometer

Specifications

Power:	10,000 hp (7,457 kW)
Torque:	68,109 lb-ft (92,344 Nm)
Speed:	2,550 rpm
Water Use*:	727 gpm (2,752 lpm)
Inertia Value**:	340 lb·ft ² (14.3 kg·m ²)
Shipping Weight:	3,550 lb (1,610 kg)

*No Cooling System

**With Companion Flange

For overhung loads, such as a belt or gear drive, please contact Taylor Dynamometer to ensure that the system will meet the required performance needs.

Recommended Accessories

- Driveshaft
- Driveshaft Guard
- Adapter Plate Kit
- Engine Cart
- Fuel Measurement Unit (FMU)
- Closed Loop Cooling Center
- Air Starter
- Throttle Control
- Water Recirculating System

Total Test Success

Optional Accessories

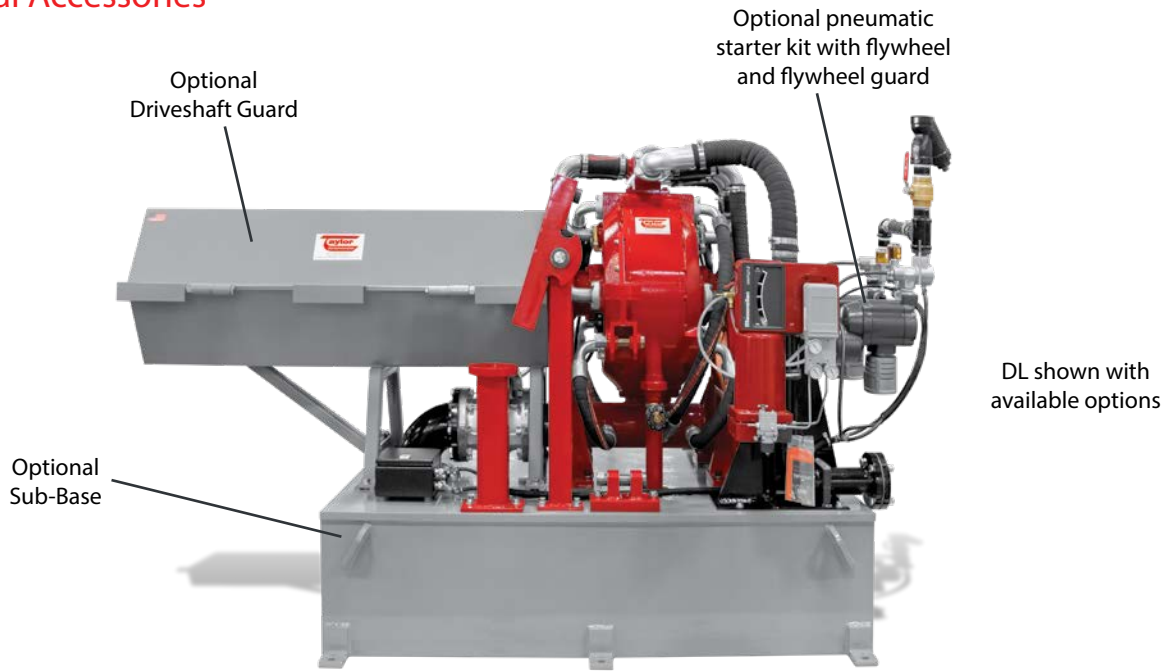

DL shown with available options



Optional Fuel Measurement Unit



Optional Engine Cart



Optional Closed Loop Cooling Center

Various Facility Support Systems and Services Available



Bulk Fuel Storage and Distribution



Coolant Storage and Distribution



Water Recirculation



Design Services



Commissioning, Start-up & Training

DL10K (US Customary)

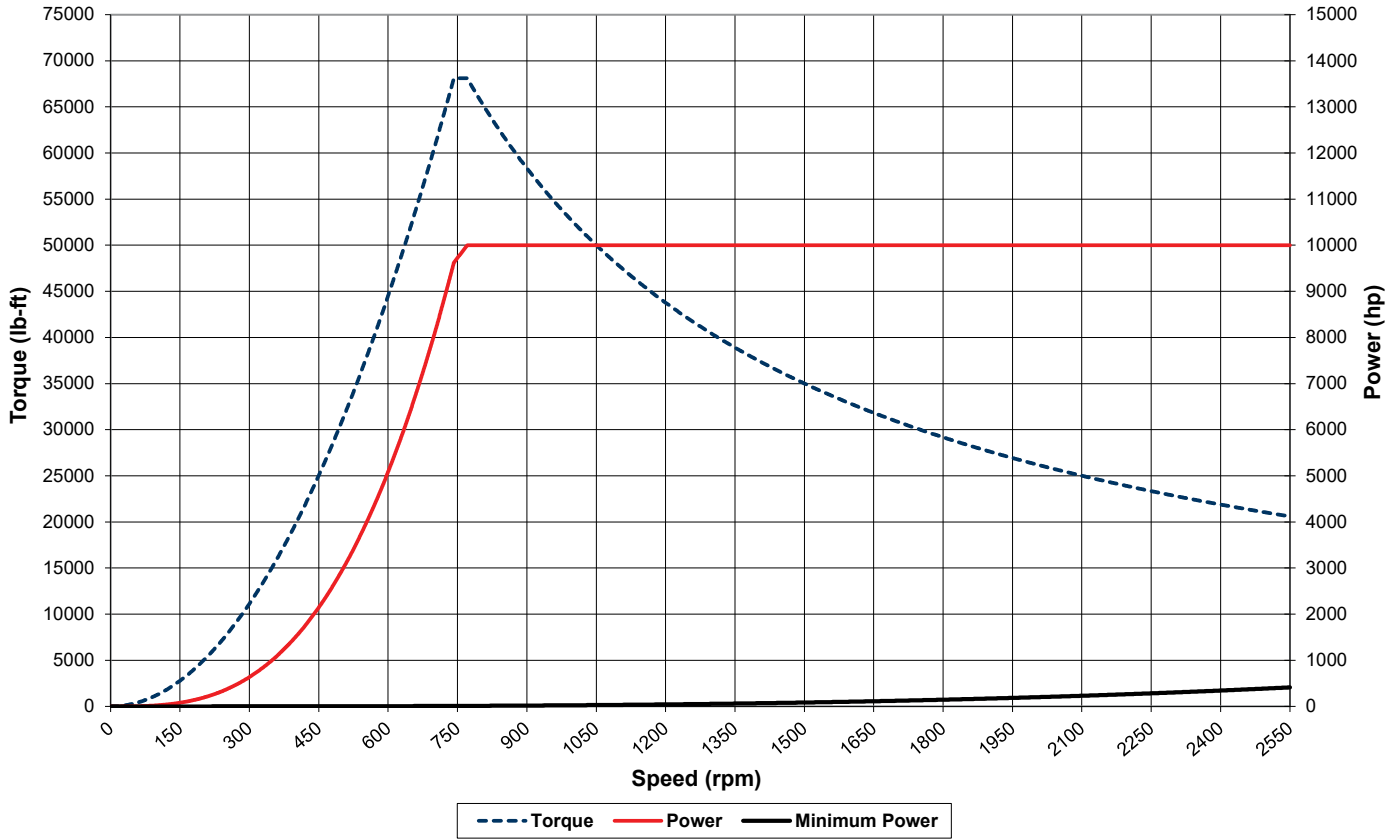

DL10K (S.I.)

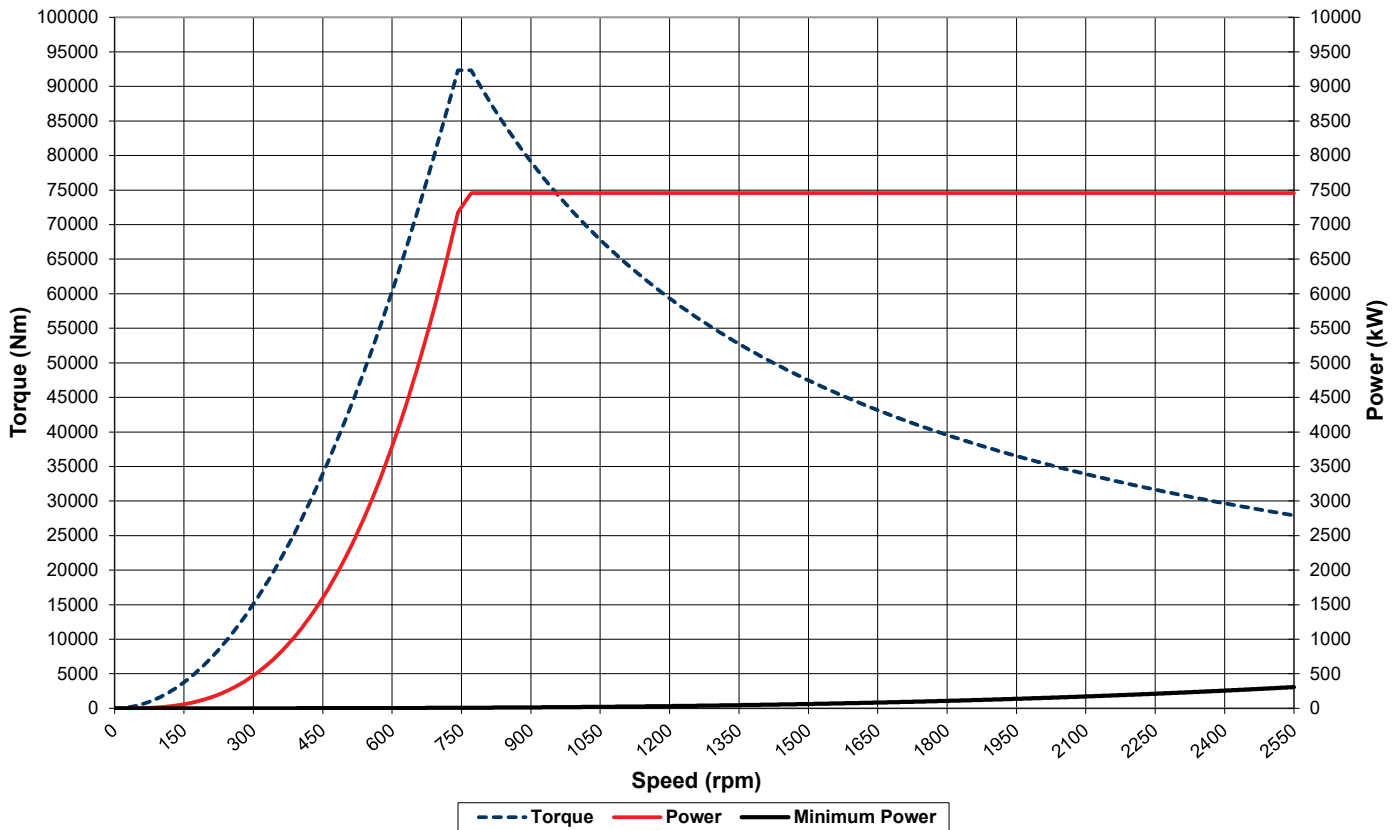

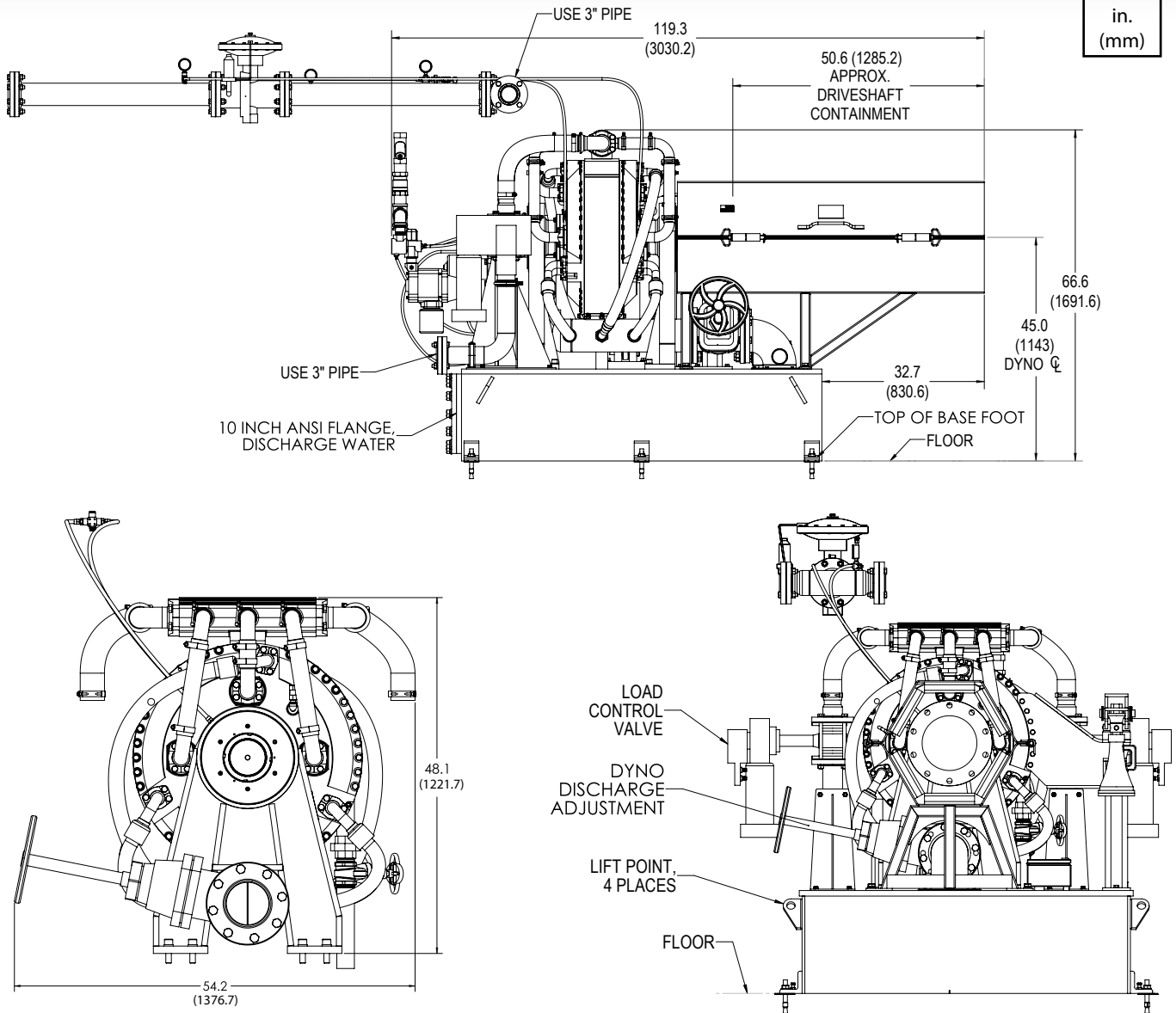

Specifications

Power:	10,000 hp (7,457 kW)
Torque:	68,109 lb-ft (92,344 Nm)
Speed:	2,550 rpm
Water Use*:	727 gpm (2,752 lpm)
Inertia Value**:	340 lb·ft ² (14.3 kg·m ²)
Shipping Weight:	3,550 lb (1,610 kg)

*No Cooling System

**With Companion Flange

As a safety precaution, Taylor Dynamometer recommends a torsional analysis to uncover any potential torsional problems that exist for each application. This analysis will identify any torsional issues (frequencies) that should be fixed prior to operation. Excessive linear vibration may also create problems that must be mitigated for continued operation. It is the customer's responsibility to ensure that these vibration issues are addressed upon application of the dynamometer. Equipment failures attributed to linear or torsional vibration are not warrantable.

Everything you need to succeed



3602 West Wheelhouse Road, Milwaukee, Wisconsin 53208 U.S.A.
(414) 755-0040 www.taylordyno.com

SMS2041v005